

DRUM WIDTH: 1400mm (55.1 in) OPERATING WEIGHT: 4600kg (10141lb) / 4900kg (10803lb)

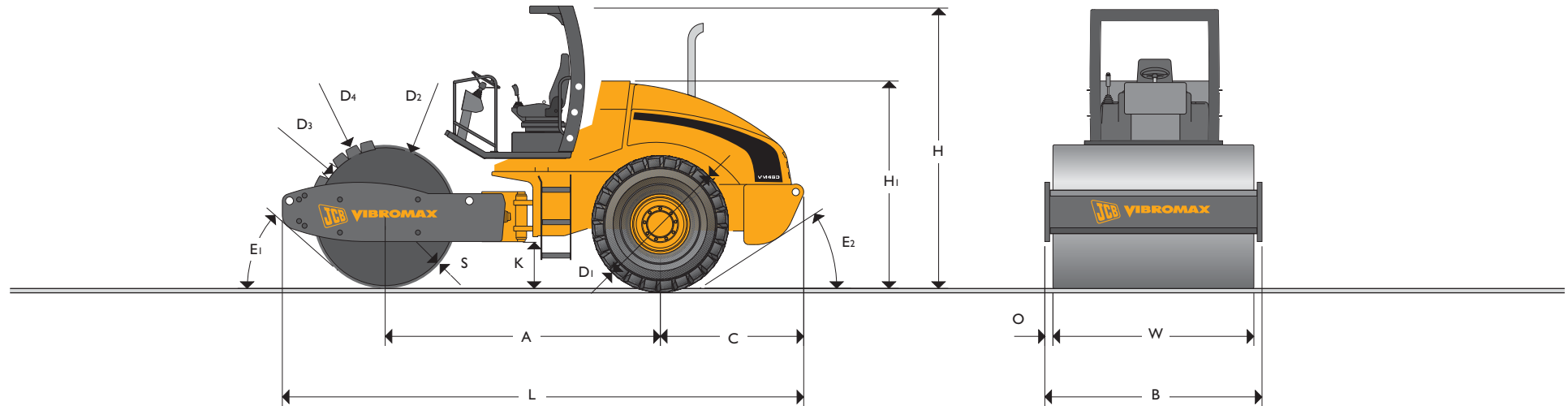

STATIC DIMENSIONS

Dimensions in millimetres (in)		
A	Wheelbase	2200 (86.6)
B	Overall width	1520 (59.8)
C	Axle to rear face	1350 (53.1)
D1	Wheel diameter	1176 (46.3)
D2	Drum diameter (smooth drum)	1000 (39.4)
D3	Inner diameter padfoot drum	910 (35.8)
D4	Outer diameter padfoot drum	1070 (42.1)
H	Total travel clearance	2640 (103.9)
H1	Height to top of seat	1915 (75.4)
K	Ground clearance	335 (13.2)
L	Total travel length	4375 (172.2)
O	Overhang	60 (2.4)
S	Drum thickness	20 (0.8)
W	Drum width	1400 (55.1)
E1	Front departure angle	37°
E2	Rear departure angle	25°

OPERATING DATA

		VM46D	VM46PD
Operating weight	kg (lb)	4600 (10141)	4900 (10803)
Operating axle load front / rear	kg (lb)	2200 (4850) / 2400 (5291)	2500 (5512) / 2400 (5291)
Operating linear load front	kg/cm (lb/in)	15.7 (88)	
Exciter frequency	Hz (vpm)	32 (1920)	32 (1920)
Nominal amplitude	mm (in)	1.8 (0.071)	1.5 (0.059)
Centrifugal force	kN (lbf)	101.6 (22841)	101.6 (22841)
Centrifugal force / drum width	N/cm (lbf/in)	726 (414)	726 (414)
Compaction depth up to	cm (in)	65 (26)	70 (28)
Working speed (forward/reverse) max.	km/h (mph)	5.8 (3.6)	5.8 (3.6)
Travel speed (forward/reverse) max.	km/h (mph)	12.7 (7.9)	12.7 (7.9)
Steering lock angle	degrees	±32	±32
Vertical oscillation	degrees	±12	±12
Inner turning radius	m (in)	3.1 (122)	3.1 (122)
Tyres		12.00 R20 XZL	12.4 - 24 Dyna Torque
Number of padfeet			77
Height of padfoot	mm (in)		80 (3.1)
Gradeability up to	degrees (%)	30 (58)	30 (58)

ENGINE

Four-cylinder, water-cooled, four-stroke, diesel engine.

		Tier III
Make		Cummins
Model		B 3.3
Piston displacement	cm ³ (in ³)	3260 (199)
Performance – DIN 6271	kW (hp)	45 (60)
Operating speed	min ⁻¹ (rpm)	2200 (2200)
Starting device		Electric motor
Air cleaner		Dry cartridge with safety cartridge
Fuel filter		Cartridge

PROPULSION

Infinitely variable hydrostatic direct drive by variable displacement motor on rear axle and drum, Multidisc self-locking differential (NoSPIN).

EXCITER DRIVE

Electrically controlled hydrostatic direct drive on drum.

EXCITER

Single-shaft circular exciter.

STEERING SYSTEM

Servo assisted center articulation with vertical oscillation.

SERVICE CAPACITIES

Fuel	litres (US gal)	180 (47.6)
Engine oil (engine)	litres (US gal)	8 (2.1)
Gear oil (exciter)	litres (US gal)	2.5 (0.7)
Hydraulic oil	litres (US gal)	60 (15.9)
Coolant	litres (US gal)	14 (3.7)

BRAKING SYSTEM

Service brake: Hydrostatic propulsion system.
Parking brake: Hydraulically released multi-disk brake on rear axle and drum drive.
Emergency brake: Electrically controlled.

ELECTRICAL SYSTEM

Voltage	V	12
Battery capacity	Ah	143
Alternator	A	max. 60

INDICATORS AND SWITCHES

Hour meter, fuel, engine temperature, engine oil pressure, battery charging current, hydraulic oil and air filter condition, parking brake, neutral position control lever, speed range selection, frequency, AVC (automatic vibration control), acoustic back-up alarm. Optional lighting, turn signal, hazard-warning lights.

